

SharpEye[™]

Model FS-1100

Triple IR3 Flame Simulator

User Guide



Legal Notice and Warranty

The SPECTREX SharpEye Optical Flame Detector described in this document is the property of Rosemount.

No part of the hardware, software or documentation may be reproduced, transmitted, transcribed, stored in a retrieval system or translated into any language or computer language, in any form or by any means, without prior written permission of Rosemount.

While great efforts have been made to assure the accuracy and clarity of this document, Rosemount assumes no liability resulting from any omissions in this document, or from misuse of the information obtained herein. The information in this document has been carefully checked and is believed to be entirely reliable with all of the necessary information included. Rosemount reserves the right to make changes to any products described herein to improve reliability, function, or design, and reserves the right to revise this document and make changes from time to time in content hereof with no obligation to notify any persons of revisions or changes. Rosemount does not assume any liability arising out of the application or any use of any product or circuit described herein; neither does it convey license under its patent rights or the rights of others.

Warranty

SPECTREX agrees to extend to Purchaser/Distributor a warranty on the SPECTREX supplied components of the SharpEye products. SPECTREX warrants to Purchaser/Distributor that the products are free from defects in materials and workmanship for a period of five (5) years, commencing with the date of delivery to Purchaser/Distributor. SPECTREX expressly excludes damage incurred in transit from the factory or other damage due to abuse, misuse, improper installation, or lack of maintenance or "Act of God" which are above and beyond its control. SPECTREX will, upon receipt of any defective product, transportation prepaid, repair or replace it at its sole discretion if found to have been defective when shipped. Said repair or replacement is SPECTREX'S sole liability under this warranty and SPECTREX'S liability shall be limited to repair or replacement of the component found defective and shall not include any liability for consequential or other damages. The customer is responsible for all freight charges and taxes due on shipments both ways. This warranty is exclusive of all other warranties express or implied.

TM380002 Rev. (Aa), August 2017

Table of Contents

Table of Contents	v
List of Figures	vi
List of Tables.....	vi
1 About this Guide	7
1.1 Release History.....	8
1.2 Glossary and Abbreviations	9
1.3 Notifications	10
2 Product Overview	11
2.1 Model and Types.....	11
2.2 Features and Benefits	12
2.3 Principles of Operation	12
2.4 Simulator Status.....	12
2.5 Product Certification	12
2.6 Simulator Structure.....	13
2.7 Certification Instructions	15
2.7.1 General Instructions.....	15
2.7.2 Special Conditions for Safe Use.....	16
3 Operation Instructions	17
3.1 Ordering Information.....	17
3.2 Unpacking.....	17
3.3 Operating Instructions	17
3.4 Detection Ranges.....	19
3.5 Charging the Battery	20
3.6 Maintenance.....	21
3.7 Troubleshooting	22
3.8 Technical Specifications	22
3.8.1 General Specifications	22
3.8.2 Electrical Specifications.....	22
3.8.3 Physical Specifications	23
3.8.4 EMI Compatibility.....	23

List of Figures

Figure 1: Flame Simulator Side View	13
Figure 2: Flame Simulator Rear View	14
Figure 3: Flame Simulator Front View	14
Figure 4: Flame Simulator Battery Replacement.....	21

List of Tables

Table 1: Flame Simulator Compatibility	18
Table 2: Detection Ranges per Detector/Flame Simulator	19

1 About this Guide

This guide describes the SharpEye Flame Simulator and its features, and provides instructions on how to operate and maintain the simulator.

**Note:**

This user guide should be read carefully by all individuals who have or will have responsibility for using, maintaining, or servicing the product.

This guide includes the following chapters:

- **Chapter 1, About this Guide**, details the layout of the guide, includes the release history, a glossary and abbreviations, and explains how notifications are used in the guide.
- **Chapter 2, Product Overview**, describes the SharpEye Flame Simulator and its features, and provides instructions on how to operate and maintain the simulator.
- **Chapter 3, Operation Instructions**, describes how to operate the simulator, including instructions regarding replacement and charging of the battery.

1.1 Release History

Rev	Date	Revision History	Prepared by	Approved by
0	January 2014	First Release	Ian Buchanan	Eric Zinn
1	May 2014	Second Release	Ian Buchanan	Eric Zinn
2	October 2014	Third Release	Ian Buchanan	Eric Zinn
3	December 2014	Fourth Release	Ian Buchanan	Eric Zinn
4	January 2015	Fifth Release	Ian Buchanan	Eric Zinn
5	February 2015	Sixth Release	Ian Buchanan	Eric Zinn
6	March 2015	Seventh Release	Ian Buchanan	Eric Zinn
7	July 2015	Eighth Release	Ian Buchanan	Eric Zinn
8	December 2015	Ninth Release	Ian Buchanan	Eric Zinn
9	March 2016	Tenth Release	Ian Buchanan	Eric Zinn
10	May 2016	Eleventh Release	Ian Buchanan	Eric Zinn
11	July 2016	Twelfth Release	Ian Buchanan	Eric Zinn
12	January 2017	Thirteenth Release	Jay Cooley	Ian Buchanan
13	February 2017	Fourteenth Release	Jay Cooley	Ian Buchanan
14	February 2017	Fifteenth Release	Jay Cooley	Ian Buchanan
15	April 2017	Sixteenth Release	Jay Cooley	Shaul Serero
Aa	August 2017	Seventeenth Release	Jay Cooley	Shaul Serero

1.2 Glossary and Abbreviations

Abbreviation/Term	Meaning
Analog Video	Video values are represented by a scaled signal
ATEX	Atmosphere Explosives
AWG	American Wire Gauge
BIT	Built-In-Test
CMOS	Complementary Metal-Oxide Semiconductor image sensor
Digital Video	Each component is represented by a number representing a discrete quantization
DSP	Digital Signal Processing
EMC	Electromagnetic Compatibility
EMI	Electromagnetic Interference
EOL	End of Line
FOV	Field of View
HART	Highway Addressable Remote Transducer – communications protocol
IAD	Immune at Any Distance
IECEX	International Electro-Technical Commission Explosion
IP	Internet Protocol
IPA	Isopropyl Alcohol
IR	Infrared
IR3	Refers to the 3 IR sensors in the VID
JP5	Jet Fuel
LED	Light Emitting Diode
MODBUS	Serial communications protocol using Master-Slave messaging
N/A	Not Applicable
N.C.	Normally Closed
NFPA	National Fire Protection Association
N.O.	Normally Open
NPT	National Pipe Thread
NTSC	National Television System Committee (a color encoding system)

About this Guide

Abbreviation/Term	Meaning
PAL	Phase Alternation by Line (a color encoding system)
P/N	Part Number
RFI	Radio Frequency Interference
RTSP	Real Time Streaming Protocol
SIL	Safety Integrity Level
UNC	Unified Coarse Thread
VAC	Volts Alternating Current

1.3 Notifications

This section explains and exemplifies the usage of warnings, cautions, and notes throughout this guide:



Warning:

This indicates a potentially hazardous situation that could result in serious injury and/or major damage to the equipment.

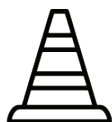

Caution:

This indicates a situation that could result in minor injury and/or damage to the equipment.



Note:

This provides supplementary information, emphasizes a point or procedure, or gives a tip to facilitate operation.

2 Product Overview

To comply with local standards and jurisdictional authorities, "end-to-end" loop testing of fire protection alarm systems, including detectors, should be performed periodically. Many safety authorities and plant managers of high-value/high-risk assets and facilities insist on quarterly "end-to-end" testing of their entire fire protection systems using an external flame simulator.

SPECTREX flame simulators emit electromagnetic radiation in a unique sequential pattern corresponding to and recognizable as fire by specific SharpEye Flame Detector models. This allows for testing under real fire conditions without the associated risks of an open flame. SPECTREX flame simulators are ATEX certified EExd for use in hazardous zones 1, 2, 21, and 22, and are powered by rechargeable lithium-ion batteries. When fully charged, the flame simulator operates for at least 1,000 tests without recharging.

Starting fires in hazardous locations is not permitted, and can be dangerous in non-hazardous locations. Using an external, portable SPECTREX flame simulator is the best means to perform a complete, functional "end-to-end" test of the detector and the fire protection system, without the need to start an actual fire. The SPECTREX flame simulator is the only non-hazardous and safe method to test the flame detector's sensors, internal electronics, alarm activation software, cleanliness of the viewing window/lens, wiring integrity, actual relay activation, and proper functionality of any other outputs used (mA, RS-485, HART).



Warning:

The Simulator is not field-repairable due to the meticulous alignment and calibration of the emitter and the respective circuits. Do not attempt to modify or repair the internal circuits or change their settings, as this will impair the system's performance and void the SPECTREX product warranty.

2.1 Model and Types

The FS-1100 Flame Simulator is compatible with several detector types:

Simulator	P/N	Compatible with:
Triple IR3 Flame Simulator	FS-1100	40/40I, 40/40UFI, 20/20MI, 20/20MPI, 20/20CTIN/P

2.2 Features and Benefits

- Used for maintenance and testing of flame detectors
- Ability to activate the flame detector from a distance of up to 12m
- Rechargeable battery included
- Operates at least 1,000 tests before battery recharge is necessary

2.3 Principles of Operation

The **FS-1100** emits IR energy, which is filtered to emit electromagnetic radiation in a unique sequential pattern, corresponding to and recognizable as a fire by the SharpEye IR3 Flame Detector.

The simulator includes a reflector that accumulates the IR energy and directs it towards the detector.

The **FS-1100** includes a laser diode and a sight for guiding the simulator to the center of the flame detector.

2.4 Simulator Status

During the first 5 seconds of operation, the laser defines the simulator's status.

Normal Status

When switching to normal status, the laser beams for 5 seconds before IR radiation is activated. These 5 seconds are used to aim the simulator to the center of the detector before activating IR radiation. IR radiation is then activated for 50 seconds. After 50 seconds, IR radiation stops and the simulator cannot operate for 20 seconds (delay between activations).

Fault Status

- **Low Battery** – The laser flashes 3 times in 3 consecutive cycles. IR radiation will be activated.
- **IR Fault** – The laser flashes 3 times in 5 consecutive cycles. IR radiation will not be activated.
- **Total Failure** – The laser does not turn on. IR radiation will not be activated.

2.5 Product Certification

The Flame Simulator Model FS-1100 is certified to ATEX and IECEx:

Ex II 2 G D

Ex db ib op is IIB + H₂ T5 Gb

Ex ib op is tb IIIC T135°C Db

–4°F to +122°F / –20°C to +50°C

The Flame Simulator Model FS-1100-R is certified per TR CU/EAC:

1Ex db ib op is IIB+H2 T5 Gb X

Ex ib op is tb IIIC T135°C Db X

-20°C ≤ Ta ≤ +50°C

This product is suitable for use in hazardous zones 1, 2, 21, and 22 with IIB + H₂ gas group vapor present.

2.6 Simulator Structure

The flame simulator is built from black-coated aluminum housing. It includes the following components:

- Reflector
- Electronic chambers
- Battery chamber
- Handle

The electronic chamber includes a PC Board with an IR source or halogen lamp. The source or lamp is assembled on the PC Board and emits light through the sapphire window.

The battery chamber includes a battery pack containing 4 lithium-ion batteries, measuring a total of 14.8VDC and 2.2Ah.

The battery pack can be replaced easily by opening the back cover. This procedure must be executed in a safe area using only a SPECTREX battery pack, P/N 380004.



Figure 1: Flame Simulator Side View

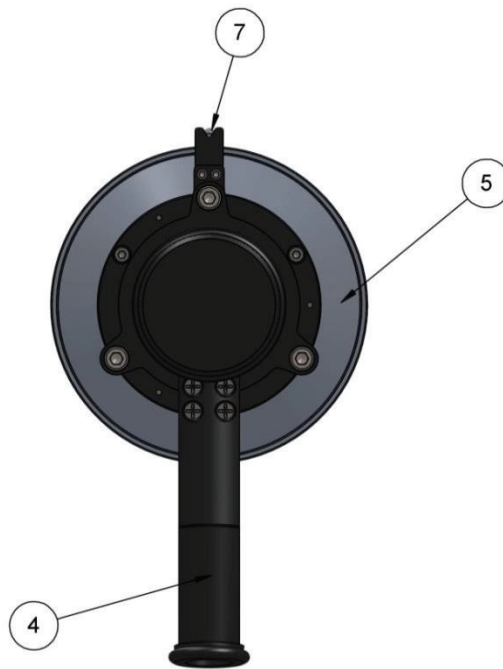

Figure 2: Flame Simulator Rear View

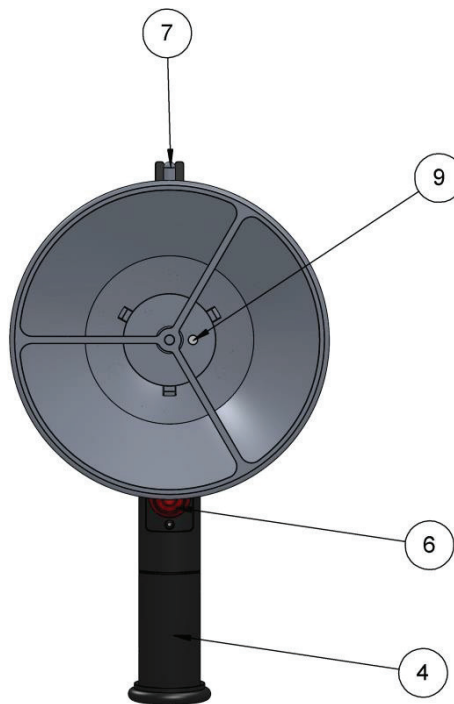

Figure 3: Flame Simulator Front View

1	Electronic Chamber	6	Push Button
2	Battery Chamber	7	Sight
3	Battery Back Cover	8	Back Cover Locking Screw
4	Handle	9	Laser Diode
5	Reflector		

2.7 Certification Instructions

2.7.1 General Instructions

The equipment marking is defined as follows:

Ex II 2 G D

Ex db ib op is IIB + H₂ T5 Gb

Ex ib op is tb IIIC T135°C Db

-20°C to +50°C / -4°F to +122°F

The equipment may be used with flammable gasses and vapors with apparatus groups IIA and IIB+H₂ T5 in the ambient temperature range of -4°F to +122°F / -20°C to +50°C.

- Inspection and maintenance of this equipment should be performed by suitable trained personnel, in accordance with the applicable code of practice, e.g. EN 60079-17.
- Repair of this equipment should be performed by suitable trained personnel, in accordance with the applicable code of practice, e.g. EN 60079-19.
- Certification of this equipment relies upon use of the following materials in its construction:
 - Enclosure: Aluminum 6061T6
 - Window: Sapphire glass
 - Seals: EPDM
- If the equipment is likely to come into contact with aggressive substances (described below), then it is the responsibility of the user to take suitable precautions (described below) to prevent the equipment from being adversely affected. This ensures that the type of protection provided by the equipment is not compromised.
- Examples of aggressive substances: acidic liquids or gases that may attack metals or solvents, or may affect polymeric materials.
- Examples of suitable precautions: routine inspections, establishing resistance to specific chemicals from the material's data sheets.

2.7.2 Special Conditions for Safe Use

The dimensions of the flameproof joints are other than the relevant minimum or maximum values required by Table 2 of IEC/EN 60079-1:2007 for IIB + H2, as detailed below:

Flamepath Description	Type of Joint	Minimum Width "L" (mm)	Maximum Gap "ic" (mm)
Joint formed by window against the enclosure	Flanged	10.75	0.02
Enclosure end-cap spigot	Cylindrical	15	0.08

Gaps should not be machined to be any larger than the values of "ic," and width should not be modified to be any smaller than the values of "L," as shown in the table above.

The equipment should only be charged in a safe area. Batteries must be removed from the flameproof enclosure. The charge conditions are as follows:

- Maximum charge voltage: 4.2V per cell
- Maximum charge current: 2200mA

The charge voltage and current should not exceed these values.

3 Operation Instructions

3.1 Ordering Information

The P/N of the Flame Simulator Kit is 380114-1.

The kit is supplied in a carry case that includes:

- Flame Simulator FS-1100
- Battery pack 380004
- Charger
- Tool Kit
- Technical Manual TM380002

3.2 Unpacking

Verify that you received the following components:

- Delivery form
- Flame simulator with integral battery
- Battery charger
- Tool keys
- User manual
- FAT forms
- EC declaration
- Storage case

3.3 Operating Instructions



Warning:

This indicates a potentially hazardous situation that could result in serious injury and/or major damage to the equipment.

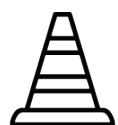

Caution:

The following test simulates real fire conditions and may activate the extinguishing system or other alarms. If this is not desired, disconnect/inhibit them before the test and reconnect after simulation.

Operation Instructions

- 1 Verify you are using the correct simulator that fits the tested detector, per the following table:

Table 1: Flame Simulator Compatibility

Simulator	Compatible with:
FS-1100	40/40I, 40/40UFI, 20/20MI, 20/20MPI, 20/20CTIN/CTIP

- 2 Verify you are at the correct distance from the detector according to the type of detector and the detector sensitivity (see *Detection Ranges* on page 19).
- 3 **For FS-1100** – Using the mechanical sight, aim the flame simulator toward the center of the detector.
Push the activate button; then use the laser spot for fine adjustment toward the center of the detector.
- 4 Keep the simulator aimed at the detector for up to 50 seconds until you trigger an alarm.
- 5 Wait 20 seconds before repeating the test.

3.4 Detection Ranges

Table 2: Detection Ranges per Detector/Flame Simulator

Model	Detector Types	Detector Sensitivity Setting (ft/m)	Testing Distance (ft/m)
FS-1100	40/40I, 20/20CTIx	50/15	6.6/2
		100/30	19.6/6
		150/45	29.5/9
		215/65	39.3/12
	40/40UFI	66/20	13/4
		133/40	26/8
		200/60	40/12
		300/90	50/15
	20/20MPI	33/10	6.6/2
		65/20	8.2/2.5
		100/30	19.6/6
		132/40	26.2/8
	20/20MI-1	33/10	N/A
		65/20	8.2/2.5
		100/30	19.6/6
		132/40	26.2/8
20/20MI-3		N/A	



Notes:

- The minimum distance from the detector is 30"/75cm.
- At extreme temperatures there is a 15% reduction in the testing range.



Warning:

Keep the flame simulator in a safe place when not in use.

3.5 Charging the Battery

The flame simulator uses lithium-ion batteries as a rechargeable power source. When the batteries are fully charged, the simulator operates at least 1,000 times without recharging. When the voltage from the batteries is lower than the required operational level, the simulator will not operate.

■ **To Charge the Battery:**

- 1 Place the flame simulator on a table in a safe area, not exceeding 104°F/40°C.
- 2 Release the locking screw (Figure 1, Item 8).
- 3 Unscrew the battery back cover counterclockwise (Figure 1 and Figure 4, Item 3).
- 4 Unscrew the locking disc clockwise (Figure 4, Item 4).
- 5 Pull out the battery from the flame simulator (Figure 4, Item 2).
- 6 Connect the battery to the charger. Verify that the charger is supplied with the flame simulator model FRIWO MPP15, with maximum charging voltage of 16.8V (4.2V x 4) and maximum current of 700mA.
- 7 Charge for a maximum of 2–3 hours, until the green LED on the charger lights.
- 8 Disconnect the charger.
- 9 Insert the battery into the flame simulator (Figure 4, Item 2).
- 10 Screw on the locking disc (Figure 4, Item 4).
- 11 Screw on the back cover (Figure 1 and Figure 4, Item 3).
- 12 Lock the back cover with the locking screw (Figure 1, Item 8).

■ **To Replace the Battery:**

- 1 Place the flame simulator on a table in a safe area, not exceeding 104°F/40°C.
- 2 Release the locking screw (Figure 1, Item 8).
- 3 Unscrew the battery back cover counterclockwise (Figure 1 and Figure 4, Item 3).
- 4 Unscrew the locking disc clockwise (Figure 4, Item 4).
- 5 Pull out the battery from the flame simulator (Figure 4, Item 2).
- 6 Insert the new battery pack in the simulator housing. Use only a SPECTREX battery pack, P/N 380004.
- 7 Screw on the locking disc (Figure 4, Item 4).
- 8 Screw on the back cover (Figure 1 and Figure 4, Item 3).
- 9 Lock the back cover with the locking screw (Figure 1, Item 8).

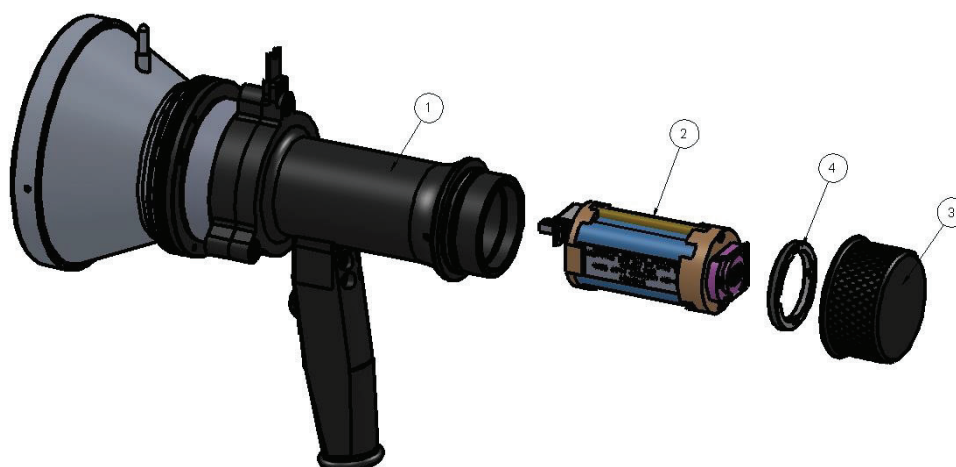

1	Simulator
2	Battery Pack
3	Back Cover
4	Locking Disc

Figure 4: Flame Simulator Battery Replacement

3.6 Maintenance

- Ensure the flame simulator is charged before operation.
- Ensure the reflector and window are clean.
- Before replacing the battery, check that you have a SPECTREX Battery Pack, P/N 380004.
- When the simulator is not in use, recharge at least every 6 months.



Warning:

Use only a SPECTREX Replacement Battery Pack, P/N 380004.

3.7 Troubleshooting

Model	Problem	Solution
FS-1100	Laser flashes 3 times	1. Recharge the battery.
	Laser flashes 5 times	1. Operate the flame simulator again. 2. Send the flame simulator for repair.
	Laser does not turn on	1. Recharge the battery. 2. Replace the battery. 3. Send the flame simulator for repair.
	Flame simulator seems to work properly but does not activate the detector	1. Verify that you are at the correct distance. 2. Verify that the flame detector is at the correct sensitivity. 3. Verify that the flame detector is operating. 4. Verify that the flame detector is clean.

3.8 Technical Specifications

3.8.1 General Specifications

Temperature Range: -4°F to +122°F / -20°C to +50°C

Vibration Protection: 1g (10–50Hz)

3.8.2 Electrical Specifications

Power: 14.8V (4 x 3.7V rechargeable lithium-ion battery)

Max. Current: 0.2A

Battery Capacity: 2.2Ah

Charging Time: 2hr at 2A

3.8.3 Physical Specifications

Dimensions: 9" x 7.3" x 5.35" / 230 x 185 x 136 mm

Weight: 5.5lb/2.5kg

Enclosure: Aluminum, heavy duty copper free, black zinc coating.

Explosion proof enclosure: ATEX and IECEx
 Ex II 2 G D
 Ex db ib op is IIB + H2 T5 Gb
 Ex ib op is tb IIIC T135°C Db
 -20°C to +50°C / -4°F to +122°F

TR CU/EAC
 1Ex db ib op is IIB+H2 T5 Gb X
 Ex ib op is tb IIIC T135°C Db X
 -20°C ≤ Ta ≤ +50°C

Water and Dust Tight: IP65

3.8.4 EMI Compatibility

Immunity Tests		
Title	Basic Standard	Level to be tested
Electrostatic Discharge (ESD)	IEC 61000-4-2	6kV/8kV contact/air
Radiated Electromagnetic Field	IEC 61000-4-3	20V/m (80MHz-1GHz) 10V/m (1.4-2GHz) 3V/m (2.0-2.7GHz)
Conducted Disturbances	IEC 61000-4-6	10 Vrms (150kHz-80MHz)
Immunity to Main Supply Voltage Variations	MIL-STD-1275B	

Emission Tests			
Title	Basic Standard	Level to be Tested	Class
Radiated Emission	IEC 61000-6-3	40dbuv/m (30-230MHz), 47dbuv/m (230MHz-1GHz)	Like Class B of EN 55022